

# The European PRISM Initiative & the OASIS coupler

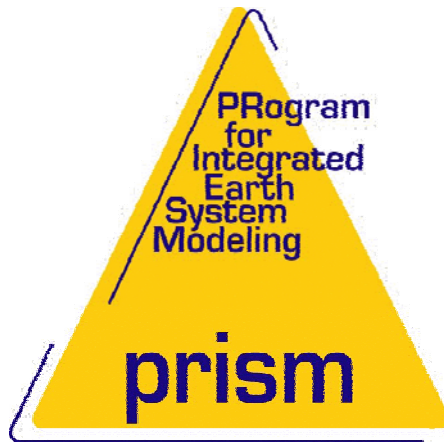

*S. Valcke, CERFACS (France)*

*R. Budich, MPI -M (Germany)*

*M. Carter, UK MetOffice (UK)*

*M.-A. Foujols, IPSL (France)*

*E. Guilyardi, CNRS (France)*

*M. Lautenschalger, MPI-M&D (Germany)*

*R. Redler, NEC-CCRLE (Germany)*

*L. Steenman-Clark, CGAM (UK)*

*N. Wedi, ECMWF*



# Outline

---

- Part I - PRISM:
  - goals & benefits
  - FP5 project and the Support Initiative
  - organisation
  - the PRISM Areas of Expertise
- Part II - OASIS:
  - historical background
  - community today
  - the OASIS3 coupler
  - the OASIS4 coupler
- Conclusions - summary



# PRISM: the goals

- Increase what Earth system modellers have in common
- Share development and support of these common tools and standards

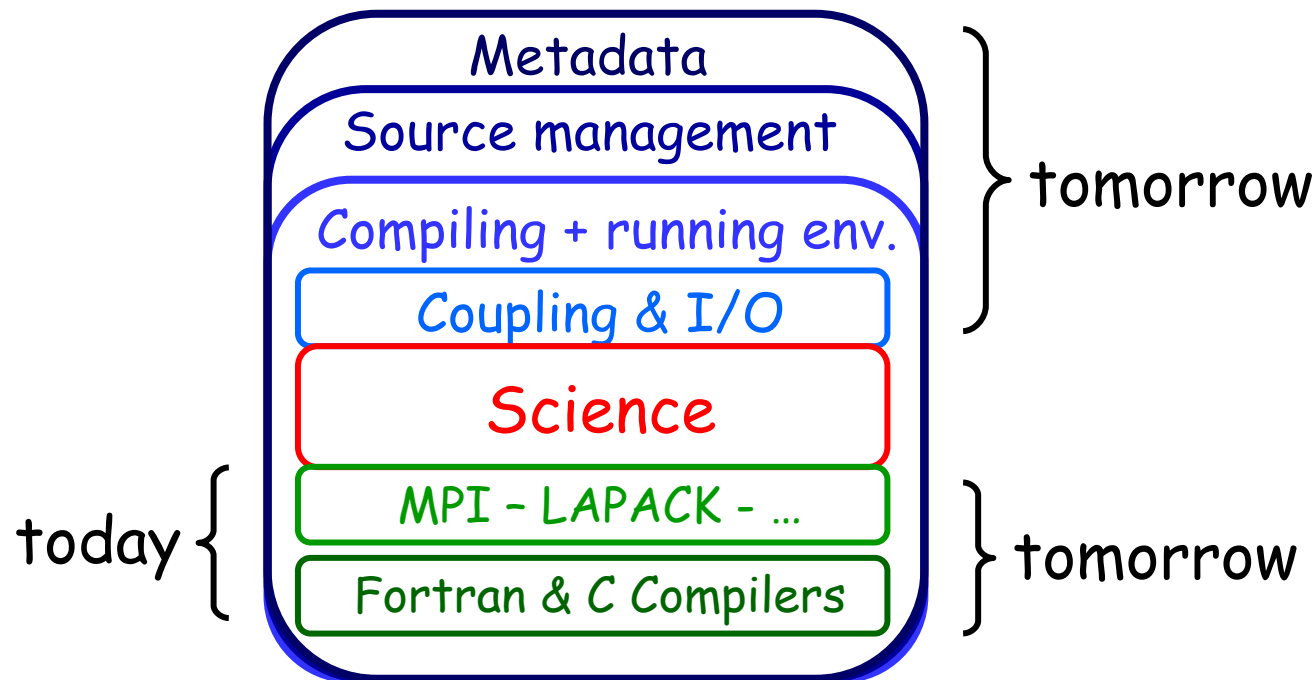



# PRISM: the benefits

---

- ❖ reduce the technical efforts of each research team
- ❖ facilitate assembling, running, and post-processing of ESMs based on state-of-the-art component models

Help climate modellers spend more time on science:



- ❖ promote key scientific diversity
- ❖ increase scientific collaboration
- ❖ stimulate computer manufacturer contribution



# PRISM: FP5 project and Support Initiative

- 2001-2004: the PRISM EU project
  - a European project funded for 4.8 M€ by the EC
  - 22 partners

- 2005-2008: the PRISM Support Initiative:

- 7 partners:

**France: CERFACS, CNRS**

**UK: CGAM, UK MetOffice**

**Germany: MPI-M&D, NEC-CCRLE**

**ECMWF**

- 9 associate partners:

**CSC (Finland)**

**IPSL, Météo-France (France)**

**SMHI (Sweden)**

**MPI-M (Germany)**

**CRAY**

**SUN**

**SGI**

**NEC-HPCE**





# PRISM: the Areas of Expertise

---

PRISM is organised around 5 "PRISM Areas of Expertise":

- Organisation of related network of experts
- Promotion and, if needed, development of software tools for ESM
- Promotion of community standards
- Coordination with other international efforts
  - ❖ Code coupling and I/O
  - ❖ Integration and modelling environments
  - ❖ Data processing, visualisation and management
  - ❖ Meta-data
  - ❖ Computing



# PRISM: the organisation

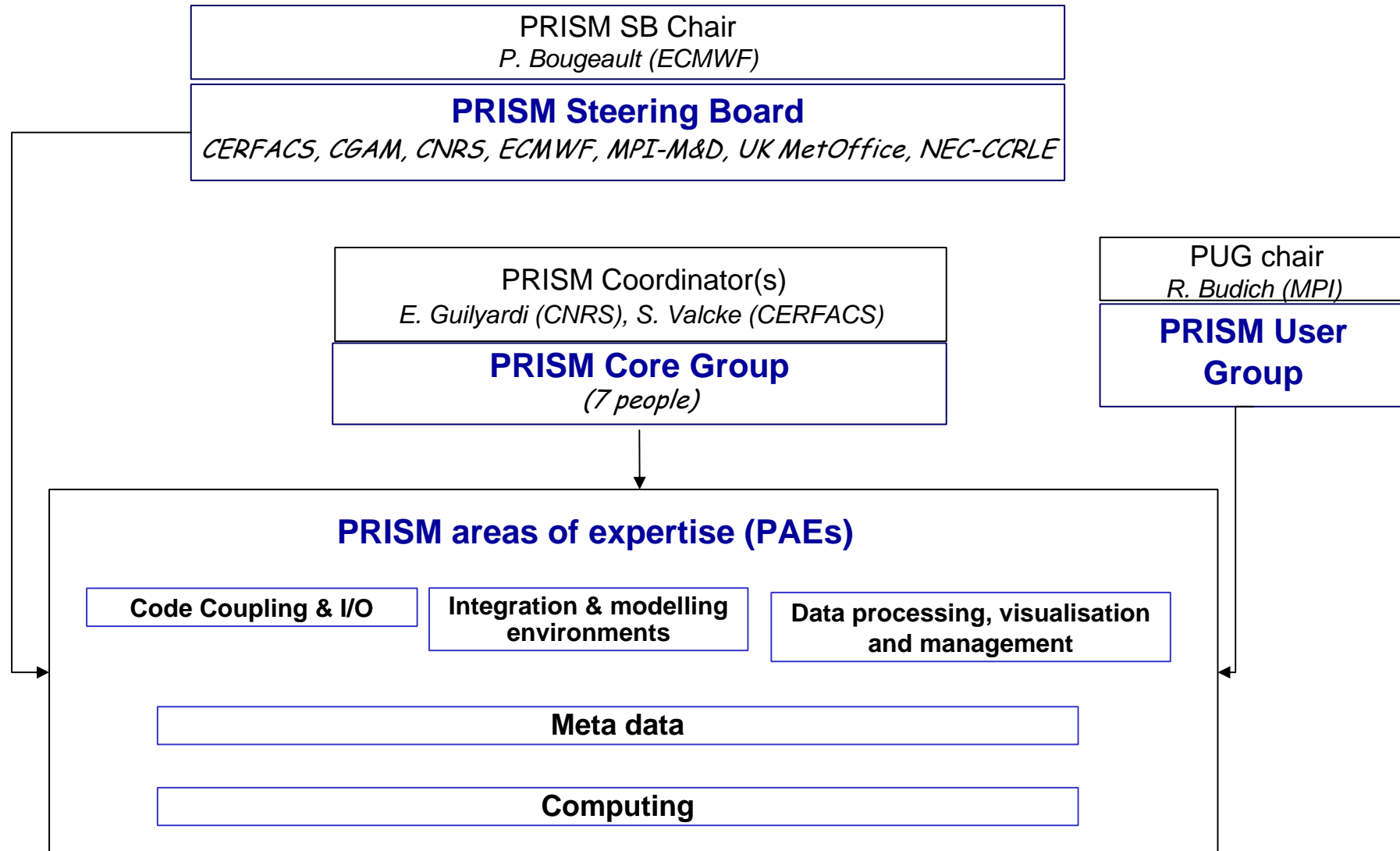



# PRISM: the Areas of Expertise

---

## PAE Code Coupling and IO

*Leader: S. Valcke (CERFACS)*

- ❖ development and support of OASIS3 and OASIS4 couplers
- ❖ technology watch on coupling tools developed outside PRISM:
  - PALM coupler (CERFACS), BFG (U. of Manchester), CCSM (NCAR), ...
- ❖ relations with projects involving code coupling:
  - UK Met Office FLUME project, US ESMF project, GENIE project, ACCESS

## PAE Integration & modelling environments *Leader: M. Carter (MetOffice)*

- ❖ source version control for software development
  - Subversion
- ❖ code extraction and compilation
  - FCM (UK MetOffice), PRISM SCE (MPI M&D)
- ❖ job configuration & running
  - prepIFS/prepOASIS4, SMS (ECMWF), PRISM SRE (MPI M&D)



# PRISM: the Areas of Expertise

---

## PAE Data processing, visualisation and management

*Leader: M. Lautenschlager (MPI-M&D)*

- ❖ data processing, visualization, archiving and exchange for Earth system
  - **NetCDF CF convention**
  - CDO (MPI-M), CDAT (PCMDI)
  - CERA-2 data model (World Climate Data Centre, MPI-M&D)
  - MARS (ECMWF)
- ❖ networking between geographically distributed archives

## PAE Computing

*Leader: M.-A. Foujols (IPSL), R. Redler (NEC-CCRLE)*

- keep computer vendors informed about climate community requirements
- keep Earth system modellers informed about computing evolutions
- ❖ Computing aspects important for Earth system modelling:  
file IO, algorithmic developments, portability (parallel and vector systems)



# PRISM: the Areas of Expertise

---

## PAE Meta-data

*Leader: L. Steenman-Clark (CGAM)*

Meta-data: data about data, models, runs, ...

... a hot topic in the last few years

- exchange and use of data
- interchangeability of Earth system models or modelling components

❖ forum to discuss, develop, and coordinate metadata issues:

- Numerical Model Metadata (U. of Reading): numerical code bases, simulations
- CURATOR project (USA) : data, codes, simulations
- Numerical grid metadata (GFDL, USA): grid
- netCDF CF convention (PCMDI and BADC): climate and forecast data files
- OASIS4 metadata coupling and IO interface
- UK Met Office FLUME project: management of model configuration



# PRISM

---

## End of Part I - PRISM



# The OASIS coupler

---

## What is a coupler?

A software tool that:

- **exchanges** (any) information between models with minimal interference in the codes
- **transforms** the coupling fields from the source model grid to the target mode grid
- contains no "science"; does not define the components

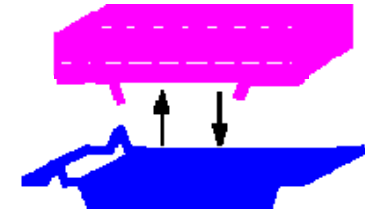

## Why use a coupler?

- change as little as possible **existing component models**
- keep the **modularity** (model development, evolution)
- keep the **flexibility** to change one or more components
- use the coupler **interpolation** and **regridding** functionality

e.g. ocean-atmosphere: 2D coupling at the air-sea interface

---



# OASIS: historical background

---

OASIS: developed since 1991 to couple existing GCMs



## OASIS1, OASIS2, OASIS3:

- low resolution, low number of 2D fields, low coupling frequency:  
→ flexibility very important, efficiency not so much!

## OASIS4:

- high resolution parallel models, massively parallel platforms, 3D fields  
→ need to optimise and parallelise the coupler



# OASIS: the community today

---

- **CERFACS** (France)

ARPEGE3 - ORCA2-LIM

ARPEGE4 - NEMO-LIM - TRIP

- **METEO-FRANCE** (France)

ARPEGE4 - ORCA2

ARPEGE3 - OPA8.1-GELATO

ARPEGE medias - OPAméd

- **IPSL- LODYC, LMD, LSCE** (France)

LMDz - ORCA2LIM

LMDz - ORCA4

- **MERCATOR** (France) (for interpolation only)

- **MPI - M&D** (Germany)

ECHAM5 - MPI-OM

PUMA - C-HOPE

ECHAM5 - E-HOPE

ECHAM5 - C-HOPE

EMAD - E-HOPE

- **ECMWF**

IFS - CTM (GEMS)

IFS - ORCA2 (MERSEA)



# OASIS: the community today

---

- IFM-GEOMAR (Germany)
- NCAS / U. Reading (UK)
- SMHI (Sweden)
- NERSC (Norway)
- KNMI (Netherlands)
- INGV (Italy)
- ENEA (Italy)
- JAMSTEC (Japan)
- IAP-CAS (China)
- BMRC (Australia)
- CSIRO (Australia)
- RPN-Environment Canada (Canada)
- UQAM (Canada)
- U. Mississippi (USA)
- IRI (USA)
- JPL (USA)

ECHAM5 - NEMO (OPA9-LIM)  
ECHAM4 - ORCA2 HADAM3-ORCA2  
RCA(region.) - RCO(region.)  
ARPEGE - MICOM  
ECHAM5 - TM5/MPI-OM  
ECHAM5 - MPI-OM  
MITgcm - REGgcm  
ECHAM5(T106) - ORCA  $\frac{1}{2}$  deg  
AGCM - LSM  
BAM3-MOM2, BAM5-MOM2, TCLAPS-MOM  
Sea Ice code - MOM4  
MEC - GOM  
GEM - RCO  
MM5 - HYCOM  
ECHAM5 - MOM3  
UCLA-QTCM - Trident-Ind4-Atlantic



# OASIS3 and OASIS4: Some key notes

---

- Developers: CERFACS, NEC CCRLE, CNRS, SGI, NEC HPCE
- Public domain; open source license (LGPL)
- Programming language: Fortran 90 and C
- Public domain libraries; :
  - external: MPI1 and/or MPI2; NetCDF/parallel NetCDF; libXML
  - included: GFDL mpp\_io; LANL SCRIP





# OASIS3 and OASIS4: Some key notes

---

To use OASIS3 or OASIS4:

- Identify your component models
- Identify the coupling fields to be exchanged between those models
- Adapt your model i.e. insert calls to OASIS communication library (PSMILe)
- Choose the coupling parameters (source and target, frequency, fields transformations, etc.) and write the configuration file
- Compile OASIS and the components models linked with PSMILe
- Start OASIS and the models and let it manage the coupling exchanges



# The OASIS3 coupler

---

- Coupler developed since more than 15 years in CERFACS
- Stable, well-debugged, but limited
- Last version: oasis3\_2-5 delivered in September 2006
- User support provided but most development efforts go to OASIS4
- Platforms:
  - Fujitsu VPP5000, NEC SX5-6-8, Linux PC, IBM Power4, CRAY XD1, Compaq, SGI Origin, SGI O3400



# OASIS3: model adaptation

---

## PRISM System Model Interface Library (PSMILe) API :

- Initialization: `call prism_init(...)`
- Grid definition: `call prism_write_grid (...)`
- Local partition definition: `call prism_def_partition (...)`
- Coupling field declaration: `call prism_def_var (...)`
- Coupling field exchange:

➤ in model time stepping loop

```
call prism_put (... , time, var_array. ...)  
call prism_get (... , time, var_array, ...)
```

- user's defined source or target (end-point communication)
- sending or receiving at appropriate time only
- automatic averaging/accumulation if requested
- automatic writing of coupling restart file at end of run



# OASIS3: coupled model configuration

---

- In text file *namcouple*:
  - total run time
  - component models
  - number of coupling fields
  - for each exchange:
    - source and target names (end-point communication)
    - coupling or I/O period
    - transformations/interpolations



# OASIS3: communication

## PSMILE based on MPI message passing

- Parallel communication between parallel models and interpolation process

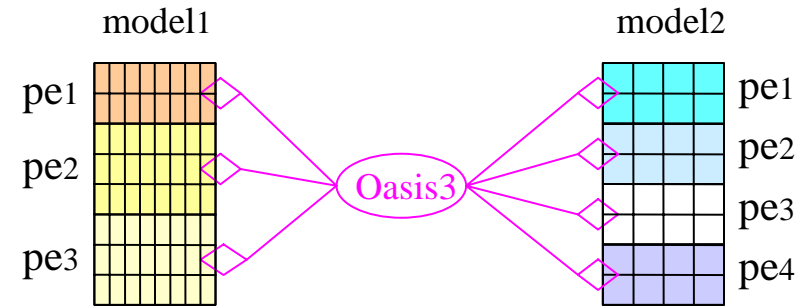

- Direct communication between models with same grid and partitioning

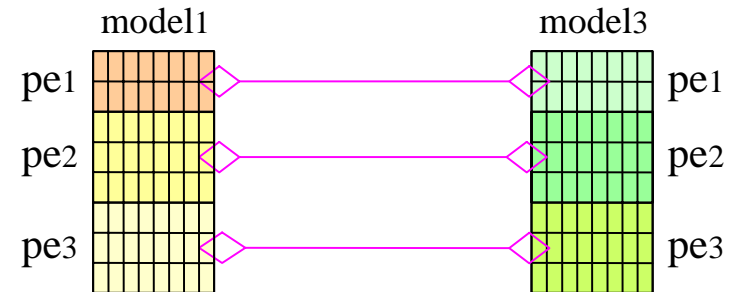

- I/O functionality (switch between coupled and forced mode):  
GFDL mpp\_io library

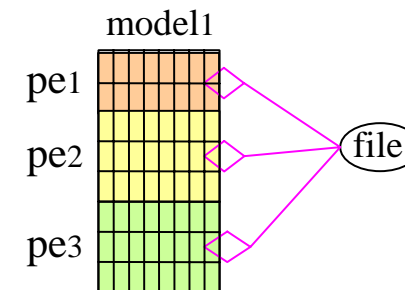

# OASIS3: interpolations/transformations

- separate sequential process Oasis3
  - ✓ neighbourhood search
  - ✓ weight calculation
  - ✓ interpolation per se during the run

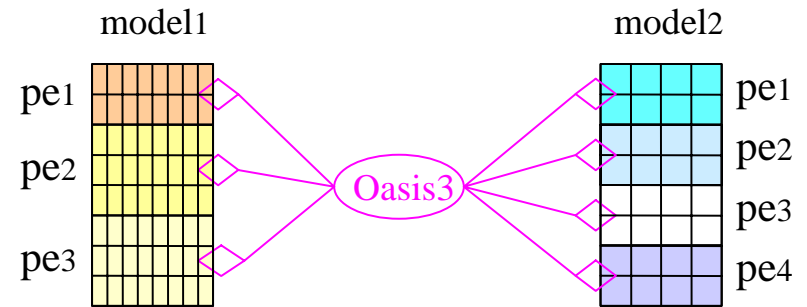

- on 2D scalar or vector fields

- SCRIP 1.4 library, RPN Fast Scalar INTerpolator:

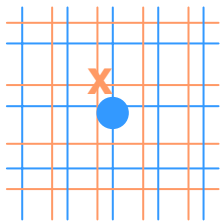

nearest-neighbour  
interpolation

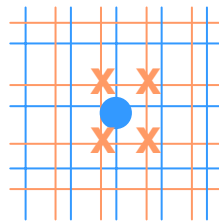

bilinear  
interpolation

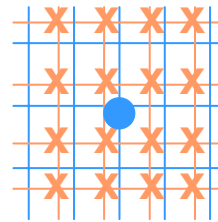

bicubic  
interpolation

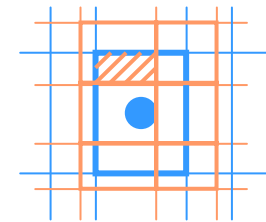

conservative  
remapping

- Other spatial transformations: flux correction, merging, etc.
- General algebraic operations

- on different types of grids: lat-lon, stretched or rotated (logically rectangular), gaussian reduced, unstructured



# The OASIS4 coupler

---

- “New” coupler developed since ~ 2003
- Beta version available
- As flexible as OASIS3 but fully parallel and more efficient:
  - Parallel communication
  - Parallel interpolation based on NEC-CCRLE multigrid algorithm



# OASIS4: model adaptation (1/3)

---

- Initialization:

```
call prism_init_comp (...)
```

- Definition of grid (3D)

```
call prism_def_grid (...)
```

```
call prism_set_corners(...)
```

- Placement of scalar points and mask on the grid:

```
call prism_set_points (...)
```

```
call prism_set_mask (...)
```

# OASIS4: model adaptation (2/3)

**Example**

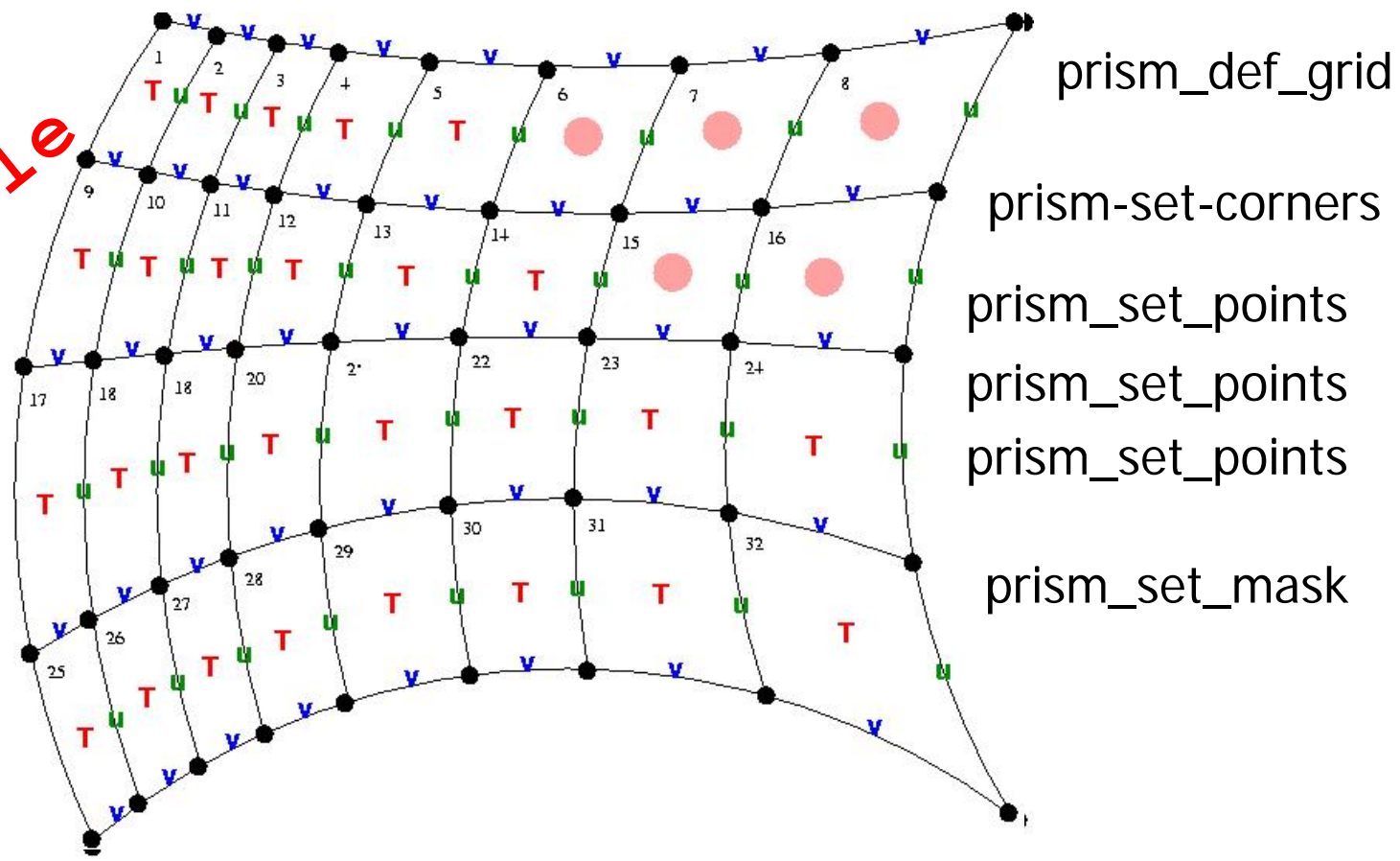



# OASIS4: model adaptation (3/3)

---

- Coupling or I/O field declaration

```
call prism_def_var(...)
```

- Coupling or I/O field sending and receiving:

- in model time stepping loop

```
call prism_put (var_id, date, date_bounds, var_array, info, ierr)
```

```
call prism_get (var_id, date, date_bounds, var_array, info, ierr)
```

- depending on user's specifications in SMIOC:

- user's defined source or target, component or file (end-point communication)
- coupling or I/O sending or receiving at appropriate times
- averaging/accumulation



# OASIS4: coupled model configuration

---

XML (Extensive Markup Language) is a text format

An XML schema:

- defines the legal content of an XML file
- gives the possibility to check the validity of an XML file

➤ **a Specific Coupling Configuration (SCC):**

- start date and end date
- applications, components for each application
- host(s), number of processes per host, ranks for each component

➤ **For each component,**

**a Specific Model Input and Output Configuration (SMIOC)**

- grid information: chosen resolution, ...
- coupling fields:
  - *name, units, valid min max, numerical type, grid*
  - input and/or output
  - source and/or target (component and/or file)
  - coupling or I/O dates
  - transformations/interpolations/combinations



# OASIS4 communication (1/2)

## Model interface library: PSMILe based on MPI1 or MPI2

- Parallel communication including repartitioning:
  - based on geographical description of the partitions
  - parallel calculation of communication patterns in source PSMILe

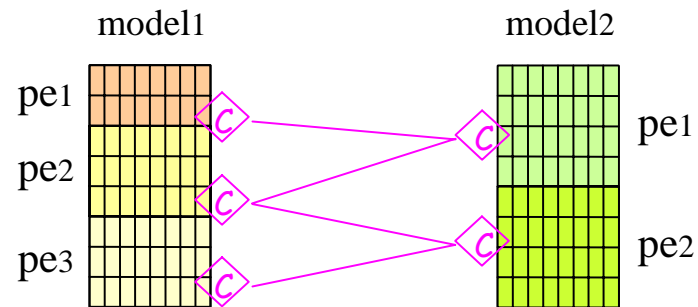

Same grid, different decomposition

- direct repartitioning

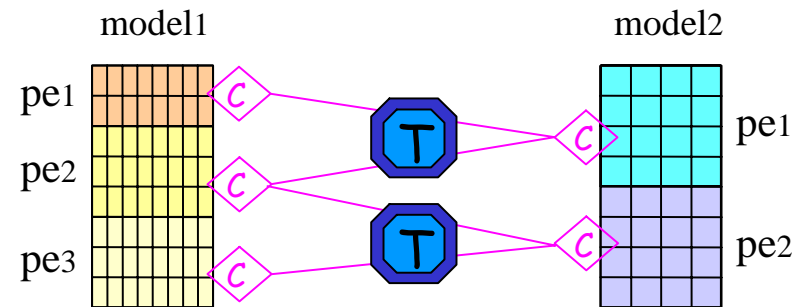

Different grid and decomposition

- interpolation in parallel Transformer

- one-to-one, one-to-many
- extraction of useful part of source field only



# OASIS4 communication (2/2)

Model interface library: PSMILe based on MPI1 or MPI2

- Parallel I/O (vector, bundles, vector bundles) : GFDL mpp\_io + parNetCDF

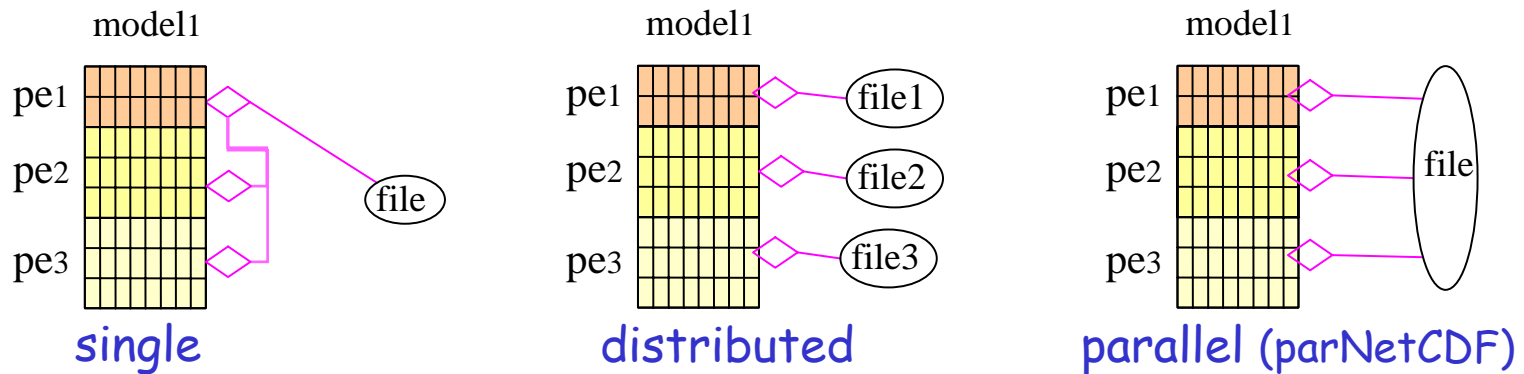



# OASIS4 regridding/transformations

---

- source time transformations (prism\_put):
  - average, accumulation
- statistics
- local transformations:
  - addition/multiplication by scalar
- interpolation/regridding (3D):
  - 2D nearest-neighbour , bilinear, bicubic
  - **3D nearest-neighbour, trilinear**
- on different types of grids:
  - regular or irregular lat-lon
  - stretched and/or rotated (logically-rectangular)
  - Gaussian reduced
  - non-geographical



# OASIS4: developments & perspectives

---

- Current developments:
  - 2D conservative remapping
  - Parallel global search for the interpolation
  - Transformer efficiency
  - Full validation of current transformations
- OASIS4 regularly tested and run with toy examples on:
  - NEC SX6 and SX8 (NEC SX compilers)
  - IBM Power4 (XL Fortran Compiler)
  - PC-Linux (Portland Group Compiler Version 6.1)
- Beta version OASIS4\_0\_2 available to beta tester groups:
  - EU project GEMS: atmospheric dynamic and chemistry coupling
  - SMHI: ocean-atmosphere regional coupling
  - UK Met Office: global ocean-atmosphere coupling (currently prototyping)
  - IFM-GEOMAR (Kiel) in pseudo-models to interpolate high-resolution fields.
- Public version available in 2007



## Part I - PRISM: summary

---

### ❖ PRISM provides:

- **network** allowing ESM developers to share expertise and ideas

(Code coupling and I/O, Integration and modelling environments, Data processing, visualisation and management, Computing, Meta-data)

- **framework promoting common software** tools for Earth system modelling

- **some standard tools** (OASIS, source management, compiling, ...)

- **visible entry point** for international coordination (metadata)

- organisation for **funding request** (hard to get money for infrastructure)

### ❖ PRISM current decentralized organisation (bottom-up approach):

☺ allows "best of breed" tools to naturally emerge

☹ relies on the developments done in the different partner groups

### ❖ Interested groups are most welcome to join !

<http://www.prism.enes.org>



## Part II - OASIS3 & OASIS4 summary

|                                    | OASIS3  | OASIS4  |
|------------------------------------|---|---|
| Development                        | stable, well tested   | new, beta version under test  |
| Model adaptation                   | Few OASIS3 PSMILe routines  | Few OASIS4 PSMILe routines<br>(more complex grid def)   |
| Configuration of the coupled model | flexible; in an external text file<br>(exchanges, frequency, transformations, ...)    | flexible; in external in XML files<br>(exchanges, frequency, transformations, ...)                              |
| Communication                      | partially parallel,<br>one-to-one   | fully parallel<br>one-to-many   |
| Interpolation                      | mono-process<br><br>2D<br>nearest-neigh., bilinear, bicubic<br>conservative remapping | fully parallel and efficient<br>(multigrid algorithm)<br><br>3D<br>nearest-neigh., bi/trilinear,<br>bi/tricubic |



# In conclusion for ACCESS

## Use of OASIS

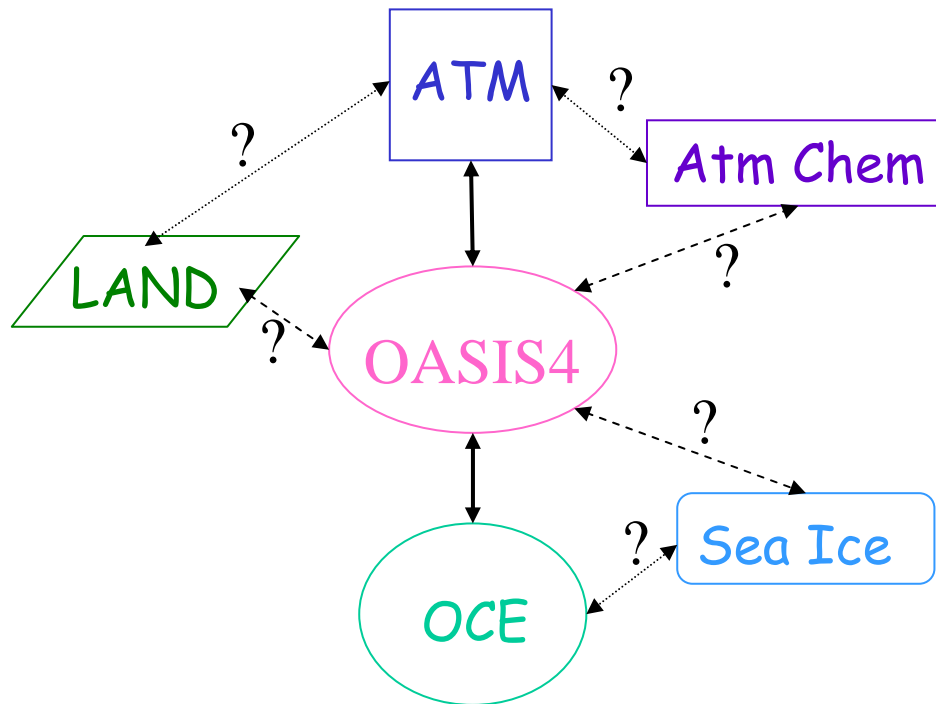

- ☺ change as little as possible existing models
- ☺ keep the modularity and the flexibility
- ☺ use coupler interpolations
- ☹ probably lose some efficiency

## Regarding PRISM: ACCESS

- ☑ shares PRISM philosophy
- ☑ uses OASIS
- ☑ uses Subversion and FCM
- ☑ uses NetCDF CF convention
- ☑ uses MARS

... so ...

ACCESS is  
already part of  
PRISM User Group!



---

# The end



# OASIS4: component model description

---

## Application and component description (XML files):

### ➤ For each application (code): **one Application Description (AD):**

- possible number of processes
- components included

### ➤ For each component in the application:

#### **one Potential Model Input and Output Description (PMIOD)**

- component general characteristics: name, component simulated, ...
- grid information: domain, resolution(s), grid type, ...
- **potential I/O or coupling variables:**
  - local name, standard name
  - units, valid min and max
  - numerical type
  - associated grid and points
  - intent -input and/or output

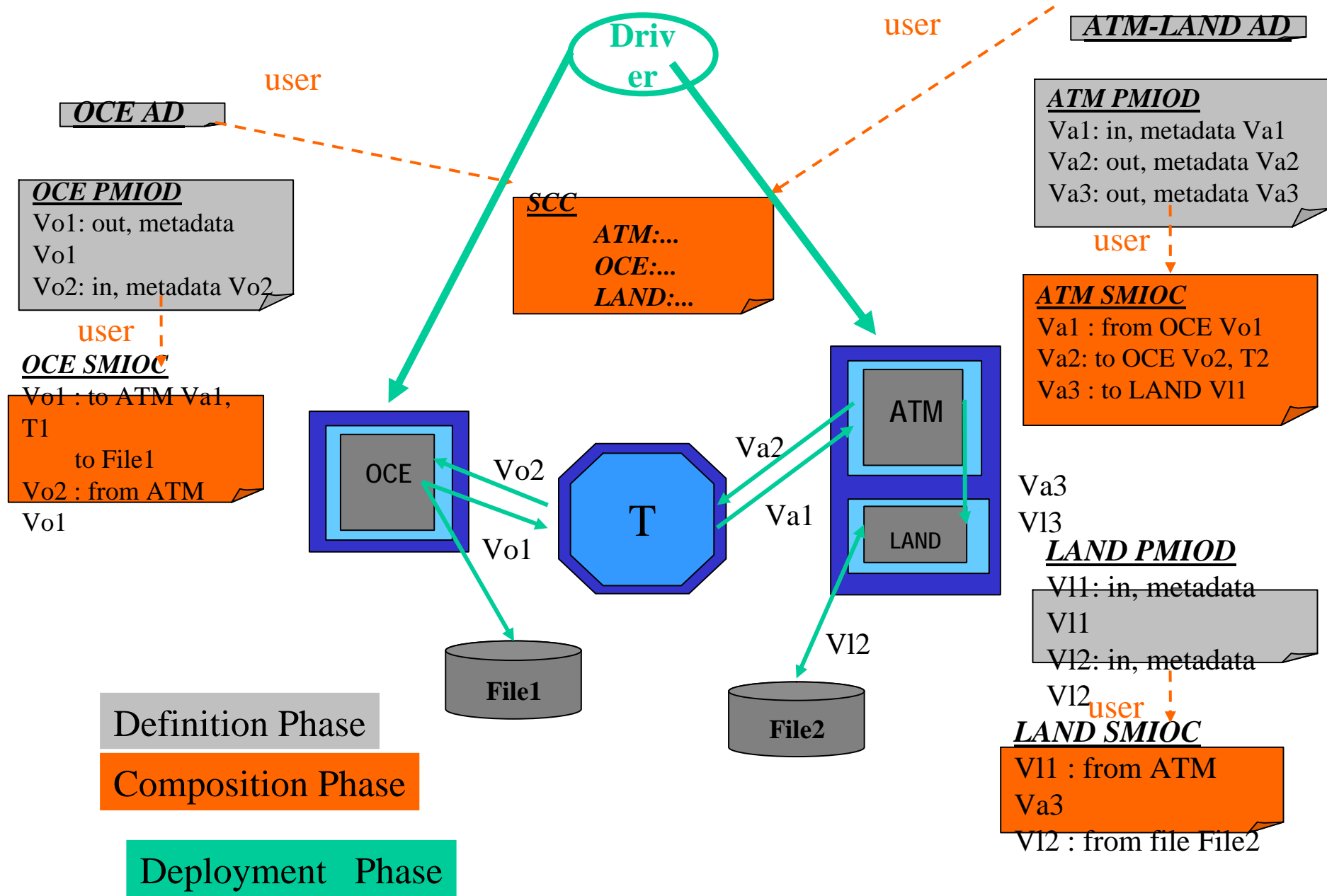



# Grids supported by OASIS4

---

- **Regridding, repartitioning, I/O:**
  - **Regular in lon, lat, vert ("Reglonlatvrt"):**
    - lon(i), lat(j), height(k)
  - **Irregular in lon and lat, regular in the vert ("irrlonlat\_regvrt"):**
    - lon(i,j), lat(i,j), height(k)
  - **Irregular in lon, lat, and vert ("irrlonlatvrt") (*not fully tested*)**
    - lon(i,j,k), lat(i,j,k), height(i,j,k)
  - **Gaussian Reduced in lon and lat, regular in the vert ("Gaussreduced\_regvrt")**
    - lon(nbr\_pt\_hor), lat(nbr\_pt\_hor), height(k)
- **Repartitioning and I/O only:**
  - "Non-geographical" fields
    - no geographical information attached
    - local partitions described in the global index space (prism\_def\_partition)
- **I/O only:**
  - **Unstructured grids ("unstructlonlatvrt")**
    - lon(npt\_tot), lat(npt\_tot), height(npt\_tot)



# What is an XML file?

- ⇒ Structured way of providing information
- ⇒ Hierarchy of elements and attributes
- ⇒ Structure of an XML file given by an XSD (schema) file

## SCC.xsd

```
...  
<xs:element name="host">  
  <xs:complexType>  
    <xs:sequence>  
      <xs:element name="nbr_procs"/>  
    </xs:sequence>  
    <xs:attribute name="local_name"  
      type="xs:string" use="required"/>  
  </xs:complexType>  
</xs:element>  
...  
<xs:element name="nbr_procs"  
  type="xs:integer" />
```

## SCC.xml

```
...  
<host local_name="host1">  
  <nbr_procs>2</nbr_procs>  
</host>  
...
```



# Oasis4: communication (2/3)

## Parallel calculation of communication patterns in source PSMILE

For each pair of source and target processes:

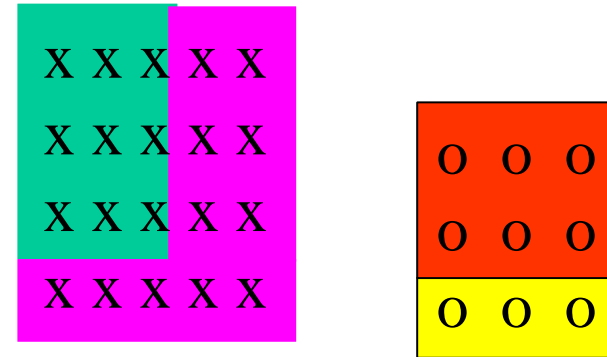

1/ Envelop exchange

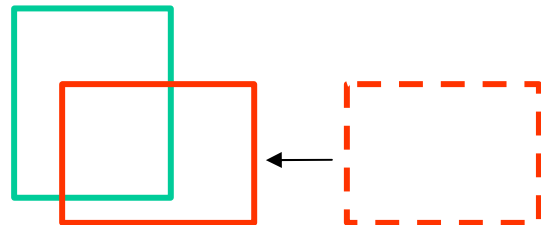

2/ Detailed neighbourhood search

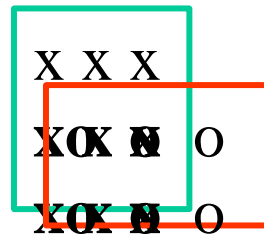

3/ EPIOS and EPIOT definition

